

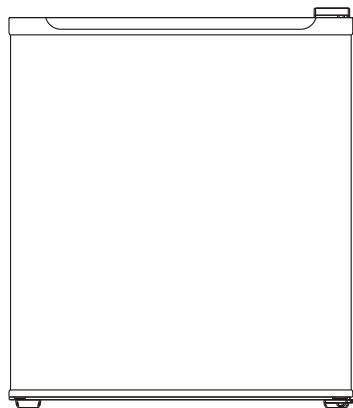

100% Australian Owned Company

BFH6



Instruction Manual

BEFORE FIRST USE

Read and follow all the instructions in this "Use and Care" even if you feel you are familiar with the product, and find a place to keep it handy for future reference.

Your attention is drawn particularly to the sections concerning "IMPORTANT SAFEGUARDS", "Care, Cleaning and Storage", and "SERVICE" statements.

For your convenience record the complete model number (located on the product identification plate) and the date you received the product, together with your purchase receipt and attach to the warranty and service information. Retain in the event that warranty service is required.

NOTE: The rating of this product (as marked on the product identification plate) is based on specific loading tests. Normal use or the use of other recommended attachments may draw significantly less power.

IMPORTANT SAFEGUARDS

When using any electrically powered product, basic safety precautions should always be followed, including the following:

PLEASE READ ALL INSTRUCTIONS CAREFULLY BEFORE USING THE PRODUCT.

WARNING! - To reduce the risk of fire, electrical shock or injury to persons or property:

- Always operate the product from a power source of the same voltage, frequency and rating as indicated on the product identification plate.
- Close supervision is necessary when the product is used by or near children or infirm persons. Do not allow children to use it as a toy.
- Do not operate any product with a damaged cord or plug, or after the product malfunctions, or is dropped or appears damaged in any way. Return the complete product to the place of purchase for inspection, repair or replacement.



IF PRESSURISED AEROSOL CONTAINERS BEAR THE WORD 'FLAMMABLE' AND/OR A SMALL FLAME SYMBOL, DO NOT STORE THEM INSIDE THE BAR FRIDGE. THERE IS A RISK OF AN EXPLOSION.

- Improper installation, adjustment, alteration, service or maintenance can cause injury or property damage. Refer to this manual. For assistance or additional information consult a qualified installer or service agent
- Keep ventilation openings, in the appliance enclosure or in the build-unstructured, clear of obstruction.
- Do not use mechanical devices or other means to accelerate the defrosting process, other than those recommended by the manufacturer.
- Do not use electrical appliances inside the food storage compartments of the appliance, unless they are of the type recommended by manufacturer.
- To reduce the risk of electric shock, do not immerse or expose the product or flexible cord to rain, moisture or any liquid other than the intended water filler and ice cube tray
- This product should not be used in the immediate vicinity of water, such as bathtub, washbaths, swimming pool etc. where the likelihood of immersion or splashing could occur.
- Never install the unit where it could be subject to:
 - * Heat sources such as radiators, heat registers, stoves or other products that produce heat.
 - * Direct sunlight

- * Excessive dust
- * Mechanical vibration or shock
- * Lack of ventilation, such as bookcase or cabinet
- * Uneven surface.
- * Moisture.
- Switch off and unplug from outlet when not in use, before assembling or disassembling parts and before cleaning. Remove by grasping the plug - do not pull on the cord.
- Do not place objects on the product or allow objects to obstruct the inlet or outlet openings, or operate in close proximity to walls or curtains, etc. The back of the appliance should be close to the wall but leaving the required distance for ventilation as stated in the installation instructions.
- Do not place naked flame sources, such as candles, on the appliance.
- Do not place vases, filled with water, on the appliance.
- Do not block any ventilation openings. Ensure that vents are not covered by newspapers, tablecloths, curtains etc. Do not install in a tight-fitting cabinet.
- After installation, the appliance should be left for 2 hours before it is switched on in order to allow the refrigerant to settle.
- Always install the refrigerator on flat and solid surface.
- Do not hang anything on the door in order to avoid the refrigerator from tilting or goods from dropping. Do not let children play with the refrigerator or hang on the door.
- Do not store or use gasoline or other flammable vapours and liquids in the vicinity of this or any other appliance.
- Do not extend or fold the power cord, keep the power cord away from compressor, because the compressor will be hot when the unit operates.
- The use of attachments or accessories not recommended or sold by the product distributor may cause personal or property hazards or injuries.
- Do not use the refrigerator outdoors. **INDOOR USE ONLY.**
- This product is intended for normal domestic/household use only.
- Make old appliances unusable prior to disposal. Pull out the mains plug, cut off the mains cable, break or remove spring or bolt catches, if fitted. By doing this you ensure that children cannot lock themselves in the appliance when playing (there is a risk of suffocation!) or get themselves into other dangerous situation.
- **COMPULSORY WARNING:** Care must be taken when disposing of this appliance in order to avoid a hazard. When you dispose of refrigerators and freezers remove any doors. Children can suffocate if they locked inside.

READ AND SAVE THESE INSTRUCTIONS

KNOWING YOUR BAR FRIDGE

PARTS AND FEATURES

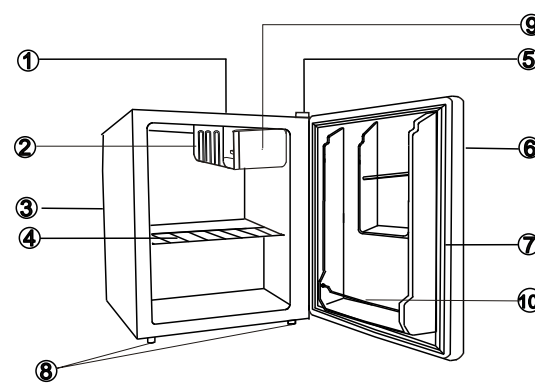

- ① Cabinet
- ② Evaporator
- ③ Thermostat Knob
- ④ Shelf
- ⑤ Hinge Cover
- ⑥ Door
- ⑦ Gasket
- ⑧ Adjustable Legs
- ⑨ Small Door
- ⑩ Door Bar

INSTALLING THE REFRIGERATOR



Before using the refrigerator, remove all the exterior and interior packaging. To ensure correct operation, this appliance must not be located where the temperature will be below 10°C or rise above 43°C.

Good Ventilation

For the purpose of easy dissipation of heat, high efficiency of refrigeration and low power consumption, a space or clearance is required around the refrigerator. The refrigerator must have at least 50mm clearance between the rear of the appliance and the wall, 100mm between the sides and wall, and the space above the top should be at least 100mm. Ensure that there is enough spacing to open the door to 160°.



Ensure that the appliance does not stand on the electrical supply cable. Parts which heat up should not be exposed. Whenever possible, the back of the appliance should be close to a wall but leaving the required distance for ventilation.

Power Supply

- The appliance is suitable for connection to 220-240Vac 50Hz supply. The Bar Fridge must be plugged into a dedicated individual 220-240Vac main socket outlet.
- Do not use an extension cord or an adapter plug.
- The main cord of the Bar Fridge is fitted with three pins plug and one of the pins is for earthing. Ensure that the electric outlet has a reliable earthed to ground. Consult a qualified electrician if you are not familiar with the electrical

Location

- Choose a place that is not too cold – the temperature should be above 10°C.
- Put the Bar Fridge in a dry place, avoiding area of high moisture and humidity.
- Do not put the Bar Fridge in frosty or unprotected areas. Example: in a garage or on a veranda.
- Do not put the Bar Fridge in direct sunlight.
- Do not put the Bar Fridge near stoves, fires, or heaters.

Stable placing

- The refrigerator must be placed on a flat and solid floor.
- DO NOT install the appliance directly on carpeting or soft material. Carpeting must be removed or protected by a metal or wood panel beneath the appliance, which extends at least the full width and depth of the appliance.
- The Bar Fridge should be levelled to eliminate vibration and rocking. If the refrigerator is rocking, this means that the floor is uneven. You will need to put some packing under one of the corner rear legs. You could use thin pieces of solid material, such as thin board, vinyl floor tiles or laminate. Place the packing so that it will sit under one of the rear legs when the refrigerator is placed into position. Ensure the refrigerator is upright and adjust the front foot to ensure a good surface contact with the floor so that the cabinet is level. Adjust the level by screwing out the appropriate level adjuster at the front, (use a suitable spanner)



This appliance is heavy. Care should be taken when moving it.

When correctly installed, your refrigerator should:

- Have adequate clearance to the back and sides for air circulation.
- Be aligned to the surrounding cupboards.
- Have doors that will self-close from a partially open position.
- Have the stability leg in place to prevent the refrigerator from tilting.

USING THE APPLIANCE

This appliance is designed for domestic use only, especially for the storage of edible food. This appliance is designed to operate in ambient temperature (surrounding air temperature) between 10°C and 43°C.



If these temperatures are exceeded, that is, colder or warmer, the appliance will not operate efficiently.

Before Use

- When using the refrigerator for the first time, remove all securing tapes.
- Wash the interior of the cabinet with warm soapy water and dry thoroughly.
- Plug the unit into a power outlet and switch on. Ensure power outlet is rated to conform to the details on the rating label.

- Adjust the thermostat knob to the max position to enable the unit to reach the required temperature quickly. The thermostat must be adjusted once the unit has reached the required operating temperature. The operating temperature is related to the room temperature, amount of food stored and the frequency of door opening. You will find the best thermostat setting after a short period of time. Setting the thermostat to 5 will cause the compressor to run longer and is the coldest setting. When turned to the 1 setting this will reduce the compressor running time and is the warmest setting.

Temperature Regulator Control Operation

The temperature regulator dial is located at the rear of the refrigerator compartment. Position "0" means OFF.

Turning clockwise in direction will turn the refrigerating unit ON

Position "1" means: Highest temperature, warmest setting.

Position "5" means: Lowest temperature, coldest setting.

At a low surround ambient temperature of around 16°C, setting "1" should be selected.

At surround ambient temperatures of around 25°C, select setting "2-3". If you require a lower temperature, select setting "4" or "5".

Note: High ambient temperatures (e.g. on hot summer days) and a cold setting on the temperature regulator (position 5) can cause the compressor to run continuously. Reason: when the ambient temperature is high, the compressor must run continuously to maintain the low temperature in the appliance.

The temperature will be affected by:

- Room temperature
- How often the door is opened
- Location of the appliance

In determining the correct temperature control setting, all these factors have to be considered and some experimentation may be necessary.



Do not allow children to tamper with the control or play with the product.

Do not use detergents, abrasive powders, highly perfumed cleaning products, wax polishes or products containing alcohol.

INTERIOR ACCESSORIES STORAGE SHELF

The unit is fitted with a wire tray storage shelf.

CARE AND MAINTENANCE

To keep your domestic refrigerator operating efficiently and safely, periodic inspection and cleaning of several components once a month is recommended.

Cleaning your refrigerator

- For safety reason, switch off and unplug the appliance from outlet before cleaning. Remove by grasping the plug - do not pull on the cord.
- Remove the shelf and wipe down. Place it in a secure place, and replace it after the interior of the refrigerator has been wiped clean.
- Wipe the inside and the outside of the refrigerator with a damp cloth, using lukewarm water.
- If the refrigerator is very dirty, wipe it with a neutral detergent first, then use a clean cloth to dry it.
- Do not use other types of detergents, cleaners, abrasive powder or solvents which may contain chemicals that could damage the lacquer coat and plastic surface of the refrigerator.

Care of Plastic Parts

5

- Ensure that the rubber door gasket is kept clean and free from dirt, grease, etc. Inspect regularly to ensure it is clean.
- If the plastic parts of the refrigerator are contaminated by oil/grease (animal or vegetable) for a long time, they will age more quickly and can become brittle and crack easily. They will also emit bad smell. Therefore, you should get the habit of cleaning it regularly.

Cleaning condenser

Dust accumulation on the condenser increases energy consumption.

The condenser at the back of the refrigerator should be carefully cleaned once a year with a soft brush or a vacuum cleaner.

Notes: After cleaning the refrigerator; check the following points:

- Are the power supply cord and the plug broken?
- Is the plug set properly?
- Is the earthing wire loose?
- Is there a block on the drainage outlet?
- Is it properly installed?

In case of power failure

- Do not place foods in refrigerator and minimize the times the door is opened.
- Due to the increase of temperature in the refrigerator chamber, it is recommended to use the foods as soon as possible to prevent them from spoiling.

Defrosting the Refrigerator

To defrost the refrigerator, simply turn the thermostat to the '0' position and remove the power plug from the power outlet. Place the drip tray under the evaporator to collect the water. Remove the food and leave the door open.

When the ice has melted, wipe the interior with a soft cloth, reset the thermostat to 5, turn the unit on and replace the food. When the unit has reached the desired temperature, reduce the thermostat setting as required.

Switching off the appliance

To switch off the appliance, turn the temperature regulator to position "0". If the appliance is not going to be used for an extended period:

- Remove all refrigerated package
- Switch the appliance by turning the temperature regulator to position "0"
- Remove the mains plug or switch off or disconnect the electricity supply.
- Clean thoroughly (see cleaning and care)
- Leave the door open to avoid the build up of odours.
- Once the unit has been turned off, allow the unit to settle down for about 10 minutes before turning the unit on. This will prevent the compressor from being damaged.

Energy Saving Hints

- Do not install the appliance close to sources of heat, such as a cooker, dishwasher or radiator.
- Locate the appliance in a cool and well ventilated room and make sure that the air openings of the cabinet are not obstructed.
- Avoid unnecessary frosting in the cabinet by packing all foodstuffs into airtight packages before placing them in the refrigerator.
- Always leave warm food to cool down to room temperature before placing it in the refrigerator.
- Try to avoid keeping the door open for long periods, or opening the door too frequently as warm air will enter the cabinet, as this will lower efficiency of the refrigerator and minimise the work of the compressor.
- Ensure there are no obstructions preventing the door from closing properly.

6

REVERSING THE DOOR SWING OF YOUR REFRIGERATOR

The side at which the door opens can be changed from the left hand side (as supplied) to the right side, if the installation site requires. Should you require reversing the opening direction of the door, please follow these instructions.



Warning! When changing the side at which the door opens, the appliance must not be connected to the mains. Remove by grasping the plug from the main - do not pull on the cord.

This bar fridge has been built with the door hinges on the right. If you wish to change the opening direction, follow the instructions below:

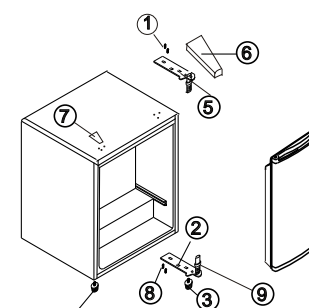

FIGURE 1

Door opening from left side

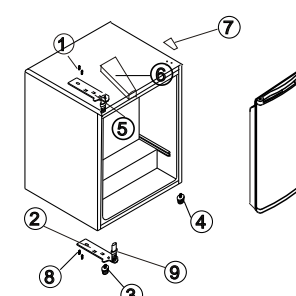

FIGURE 2

Door opening from right side

- Remove the upper hinge cover (6)
- Remove the two screws (1) that hold the upper hinge (5) (right side) to the frame. Take away the upper hinge (5).
- Lift the door and place it on a padded surface to prevent scratching.
- Remove the two screws (8) that hold the lower hinge (2). Remove the lower hinge (2). If there is originally a washer on the hinge pin, it must remain there when reversing.
- Where appropriate or necessary, remove the front levelling legs (4) for convenient reversing the lower hinge and remember to install them after reversing.
- Remove the plug buttons (7) for holes to the right side.
- Set the door in its place making sure it sits on the door seat at the lower hinge (2).
- While holding the door in the closed position secure the upper hinge (5) on the top left hand side with the two screws (1). Do not tighten the two screws (1) until the door is well aligned with the cabinet. Adjust the lower hinge (2) as well if necessary for aligning the door.
- Install the upper hinge cover (7) on the upper hinge.

NORMAL OPERATING SOUNDS

The following noises are characteristic of refrigeration appliances:

Clicks: Whenever the compressor is switched on or off, a click can be heard.

Humming: As soon as the compressor is in operation, you can hear it humming.

Bubbling/Splashing: When refrigerant flows into thin tubes, you can hear bubbling or splashing noises. Even after the compressor has been switched off, this noise can be heard for a short time.

7

TROUBLE SHOOTING GUIDE

When there is something wrong with your refrigerator, check the following points before asking for repair.

PROBLEM	CAUSE	REMEDY
The Appliance does not operate	The Appliance is not switched ON	Switch ON the appliance.
	Mains plug is not plugged in or is loose	Insert mains plug.
	Fuse has blown or is defective	Check fuse, replace if necessary.
	Socket is defective	Mains malfunctions are to be corrected by an electrician.
Appliance cools too much	Temperature is set too cold.	Turn the temperature regulator to warmer setting temporarily.
	Temperature is not properly adjusted.	Please check the " USING THE APPLIANCE " section to learn how to adjust the temperature regulator.
Food is too warm	Door was opened for an extended period of time.	Open the door only as long as necessary.
	A large quantity of warm food was placed in the appliance within the last 24 hours.	Turn the temperature regulator to a cooler setting temporarily.
	The appliance is near a heat source.	Please check the " USING THE APPLIANCE " section to learn how to adjust the temperature regulator to offset the heat source, or find another suitable place.
Heavy build up of frost, possibly on the door seal.	Door seal is not air tight (possibly after reversing the door).	Carefully warm the leaking sections of the door seal with a hair dryer (on a cool setting). At the same time shape the warmed door seal by hand such that it sits correctly.
Unusual noise	Appliance not level.	Readjust the foot
	Appliance is touching the wall of others.	Move the appliance slightly.
	A component, e.g. a pipe on the rear of the appliance is touching another part of the appliance or the wall.	If necessary, carefully bend the component out of the way.
The compressor does not start immediately after changing the temperature setting.	This is normal, no error has occurred	The compressor starts after a period of time.
Water on the floor or on the storage shelves	This is normal because of condensation	Wipe the floor with a dry cloth

8

FOR YOUR SAFETY

- Always check full refrigerator operation as detailed above before returning the unit as faulty
- It is not advised to loosen any parts which are fixed by screw, contact the manufacturer for advice.
- Do not operate the unit with a damaged cord or plug, or after the unit malfunctions, or is damaged in any manner. Return the **complete** unit to the place of purchase for in-warranty replacement, or inspection and repair.
- CAUTION: To reduce the risk of electric shock, **DO NOT** remove the cover (or back) whilst the unit is in operation or connected to the mains supply.
- In some products, the replacement of flexible cords by the user is not intended. Special tools are required to safely replace the cord. Return the **complete** product for inspection and repair.

DANGER! Never try to repair a faulty – or what is thought to be a faulty machine yourself. This can jeopardize your life or the lives of subsequent users. Leave repairs to electrical equipment to authorized technicians.



DO NOT

DO NOT

DO NOT

OPERATE THIS APPLIANCE BEFORE READING THE INSTRUCTION BOOKLET
PLACE ARTICLES ON OR AGAINST THIS APPLIANCE
STORE CHEMICALS OR FLAMMABLE MATERIALS OR SPRAY AEROSOLS NEAR THIS APPLIANCE

R600a Refrigerant Warning

- This appliance contains a small quantity of R600a refrigerant which is environmentally friendly, but flammable. It does not damage the ozone layer, nor does it increase the greenhouse effect.
- During transportation and installation, ensure that the tubing of the refrigerant circuit is not damaged.
- Leaking refrigerant can ignite and may damage the eyes.
- In the event any damage does occur, avoid exposure to open fires and any device which creates a spark. Disconnect the appliance from the mainspower.
- Thoroughly ventilate the room in which the appliance is located for several minutes.
- The room for installing the appliance must be at least 1 cubic metre per 8 grams of refrigerant. The refrigerant quantity contained in this appliance is noted on the Rating Plate of the appliance.

9

SERVICE AND WARRANTY

You will be covered by a 1-year manufacturer's in-house warranty and 3 months commercial use warranty.

Your refrigerator is guaranteed against faulty materials and assembly. In the event that warranty service is required, the information provided in this instruction book and the warranty card should be followed. The Warranty Card should be completed at time of purchase and retained with your receipt in the event that warranty service is required.

SERVICING AGENTS: - AUSRepair

Tel: 1300 788 822

GAF Control (Sales) Pty Ltd
18 Taras Avenue (PO Box 19)
Altona North, Victoria, 3025
Tel: 1300 767 041

READ AND SAVE THESE INSTRUCTIONS

10

技术要求

1. 纸张尺寸是420x420mm;
2. 说明书不裁切，以折页形式体现;
3. 纸张材质：80g以上的双胶纸。