

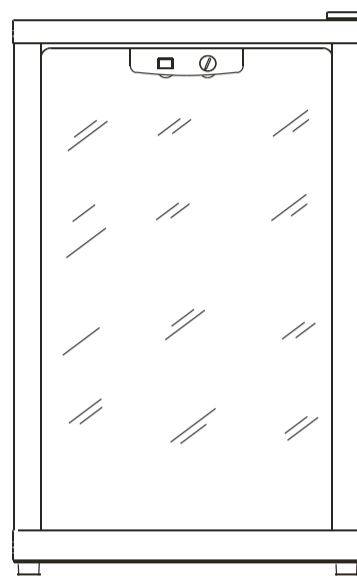

100% Australian Owned Company

# HBC115B Beverage Refrigerator



USER'S INSTRUCTIONS

## Contents

Guide to the Appliance	2
Caring for the Environment	3
Safety Information and Warnings	4
Getting Started	7
Basic Set Up	9
Reversing the Door Swing	10
Troubleshooting	11
Care and Maintenance	13

## Guide to the Appliance

NOTE: Due to production improvements, the unit you purchased may vary slightly from the below sketch.

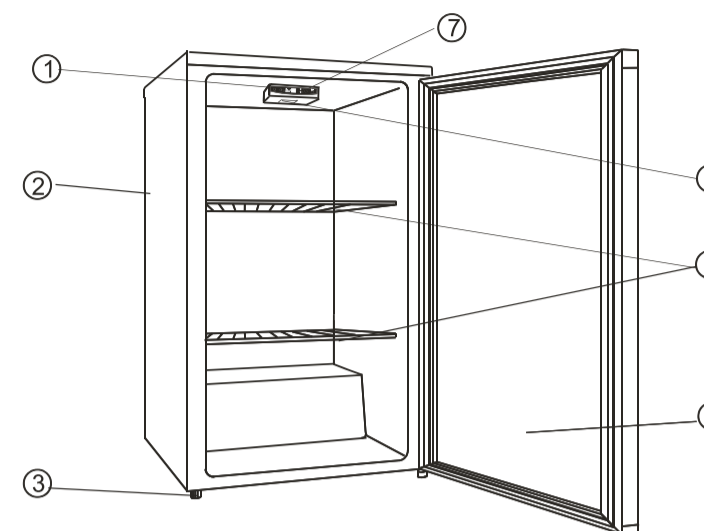

1. LAMP SWITCH
2. CABINET
3. LEVELLING LEGS
4. GLASS DOOR
5. SHELVES
6. INTERIOR LAMP
7. THERMOSTAT KNOB

2

## Caring for the Environment

### Responsible disposal of the packaging

The packaging of your appliance has been selected from environmentally friendly materials and can usually be recycled. Please ensure these are disposed of correctly.

Plastic wrapping can be a suffocation hazard for babies and young children, please ensure all packaging materials are out of reach and are safely disposed of. Please ensure they are offered for recycling rather than throwing these materials away.

### Responsible disposal of the appliance

At the end of its working life, do not throw this appliance out with your household rubbish. Electrical and electronic appliances contain materials and substances which, if handled or disposed of incorrectly, could be potentially hazardous on the environment and human health.

Observe any local regulations regarding the disposal of electrical consumer goods and dispose of it appropriately for recycling and recovery of the refrigerant. This appliance contains the flammable refrigerant isobutane (R600a) and cyclopentane (R141b) in the cabinet insulation, and must be disposed of in a separate waste collection. Contact your local authorities for advice on recycling facilities in your area.

Take care not to damage the pipework at the back of the appliance before or during transportation so that the refrigerant gas cannot escape.

The plug must be rendered useless and the cable cut off directly behind the appliance or the machine to prevent misuse.

**DANGER.** Risk of child entrapment: When discarding a fridge or freezer, make sure to take off the door and the spring action or bolt catch. Leave the shelves in place so that children cannot easily climb in, get trapped inside and suffocate.

3

## Safety Information and Warnings

Read this manual thoroughly before first use, even if you are familiar with this type of product. We have provided many important safety statements in this manual concerning the use of this appliance. Always read and observe all safety statements. They reduce the risk of fire, electric shock and injury when correctly adhered to.

Keep the manual in a safe place for future reference, along with the purchase receipt.

If applicable, pass these instructions on to the next owner of the appliance.



Pay particular attention to safety messages that follow this safety alert symbol or the words **DANGER**, **WARNING** or **CAUTION**. These words are used to alert you to a potential hazard that can seriously injure you and others.

The instructions will tell you how to reduce the chance of injury and let you know what can happen if the instructions are not followed.

**DANGER** means that failure to read this safety statement may result in severe personal injury.

**WARNING** means that failure to read this safety statement may result in extensive product damage or serious personal injury.

**CAUTION** means that failure to read this safety statement may result in minor or moderate personal injury, property or equipment damage.



CAUTION:  
Flammable Gas

This symbol alerts you to take care as the appliance contains a flammable refrigerant. Do not expose it to high heat, sparks or open flames.

We assume no liability for any eventual damages caused by misuse of the appliance or non-compliance with the instructions in this manual.

4

## Safety Information and Warnings



### Installation

**Heavy:** This appliance is heavy, take care when moving it. To avoid back or other injury, consider a two person lift or mechanical aid when installing it.

**Location:** The room for installing appliance must be at least 1M<sup>3</sup> per 8g of refrigerant. The amount and type of refrigerant in the appliance can be found on the rating plate on the back of the appliance.

**Moisture:** Install the refrigerator in an indoor area protected from wind, rain, water spray or drips.

**Heat:** Do not install it next to an oven, grill or other source of high heat.

**Ventilation:** To ensure proper ventilation, the front of the unit must be completely unobstructed. Keep any ventilation openings clear of obstructions. Choose a well ventilated area with temperatures above 16°C and below 32°C.

**Refrigerant circuit:** Do not damage the refrigerant circuit.

**Level:** Install the appliance on a level surface or adjust the feet to level the unit and ensure proper operation.

**Pipes:** Make certain that the pipes are not pinched, kinked or damaged during installations. Check for leaks after connection.

### Electrical safety

**Voltage:** Make sure your outlet voltage and circuit frequency correspond to the voltage stated on the appliance rating label. Plug the refrigerator into a 220-240V, 50Hz, 3-prong, power outlet with a 15A fuse at the mains. The outlet must be properly earthed to the ground.

**Separate circuit:** Do not use an adaptor; do not use an extension cord. We recommend you connect the refrigerator to a separate circuit serving only this appliance. This provides the best performance and prevents overloading the house wiring circuits that could cause a fire hazard from overheating. Use a power point that cannot easily be turned off accidentally.

**Power cord:** Do not kink or damage the power cord. Do not leave it exposed or dangling. Secure it behind the unit so no one steps on or places anything on the cord or against it. Never unplug the unit by pulling the cord. Always grip the plug firmly and pull straight out from the power point.

**Damaged cord:** Do not use a cord that shows cracks or abrasion damage along its length or at either end. If the supply cord is damaged, it must be replaced by the manufacturer, its service agent or similarly qualified persons in order to avoid a hazard. Contact the after sales support line to have it replaced.

**Electrical work:** If the installation of this appliance requires any electrical work, make sure it is carried out by a qualified electrician.

5

## Safety Information and Warnings



### Usage conditions and restrictions

Do not store explosive substances such as aerosol cans with a flammable propellant in this appliance. This appliance is only suitable for beverages. It is not suitable for food storage.

This appliance is intended to be used in household and similar applications such as:  
– staff kitchen areas in shops, offices and other working environments;  
– farm houses and by clients in hotels, motels and other residential type environments;  
– bed and breakfast type environments;  
– catering and similar non-retail applications.

**Indoor domestic use only:** This appliance is intended for indoor household use only. It is not suitable for commercial, industrial or outdoor use.

**Intended purpose:** Do not use this appliance for anything other than its intended purpose and only use it as described in this manual. Do not attempt to alter or modify this appliance in any way.

**Electrical type appliances:** Do not use any such appliances inside the food storage compartments of the appliance, unless they are specifically recommended in this manual.

**Usage restrictions:** The appliance is not intended for use by persons (including children) with reduced physical, sensory or mental capabilities, or lack of experience and knowledge, unless they have been given supervision or instruction concerning use of the appliance by a person responsible for their safety.

**Children:** Supervise children to ensure they do not play with the refrigerator. Never allow children to operate, play with or crawl inside the refrigerator.

### Cleaning and maintenance

**Disconnect:** Unplug the refrigerator or disconnect power before cleaning or servicing. Failure to do so can result in electrical shock, injury or death. Do not connect or disconnect the electric plug when your hands are wet.

**Flames:** Do not let open flames or ignition sources enter the appliance.

**Flammable/explosive substances:** Never clean this appliance with flammable fluids. Do not store or use volatile, flammable or explosive propellants or liquids close to this or any other appliance. The fumes can create a fire hazard or explosion caused by electric sparks.

**Solvents:** Do not use solvent based cleaning agents or abrasives on the interior. These cleaners may damage or discolour the interior.

**Defrosting aids:** Do not use mechanical devices, steam cleaners or other means to accelerate the defrosting process. Never use a sharp or metal instrument to remove frost as it may damage the cooling system and will void the warranty. We recommend using a plastic scraper.

**Service:** Do not attempt to repair or replace any part of the refrigerator unless it is specifically recommended in this manual. Refer all other servicing to a qualified technician, or contact the after sales support line for advice on repair or replacement. It is hazardous for anyone other than an Authorised Service Person to service this appliance. In Queensland - the authorized Service Person MUST hold a Gas Work Authorisation for hydrocarbon refrigerants, to carry out Servicing or repairs which involve the removal of covers.

6

## Getting Started

### Before first use

- Unpack the appliance but keep all packaging materials until you have made sure your new refrigerator is undamaged and in good working order.
- Plastic wrapping can be a suffocation hazard for babies and young children, so ensure all packaging materials are out of their reach.
- Check to ensure you have all the parts listed on the 'Guide to the Appliance' page, plus an instruction manual and a warranty certificate.
- Read this manual to familiarise yourself with all the parts. Pay particular attention to the safety instructions on the previous pages.
- Unwind the cord to its full length and inspect it for damage. Do not use the appliance if the appliance or its cord have been damaged. In case of damage, contact our after sales support line for advice on examination, repair or return of the damaged product.
- Make sure the refrigerator is disconnected from the power supply before cleaning the interior surfaces with lukewarm water using a soft cloth to remove any dust from transit and storage. Dry the appliance thoroughly.
- Your refrigerator has the capability of the door opening from the right or left side. If your setup requires reversal of the door swing, follow the instructions on page 10.
- Your new beverage fridge is now ready for use – see page 9 for set up instructions.

**Overloading the beverage center will affect cold air circulation and cooling performance. We therefore recommend you only load the beverage center up to about 70% of its storage volume and do not use containers that are too large and block ventilation openings.**

### Installing the refrigerator

- Before installing your new upright beverage fridge, read all safety instructions in this manual, especially the sections on electrical safety and installation. Then follow the instructions below.
- This appliance is designed to be freestanding only and should not be recessed or built in.
- Place the beverage fridge on a sturdy, level floor that is strong enough to support the unit when it is fully loaded.
- DO NOT install the appliance directly on carpeting or soft material. Carpeting must be removed or protected by a metal or wood panel beneath the appliance, which extends at least the full width and depth of the appliance.
- **NOTE:** Ensure that the appliance does not stand on the electrical supply cable. Parts which heat up should not be exposed. Whenever possible, the back of the appliance should be close to a wall but leaving the required distance for ventilation.

7

## Getting Started

- Locate the beverage fridge
  - Away from direct sunlight, which may affect the acrylic coating.
  - Away from sources of heat (stove, heater, radiator, dishwasher, etc.), which may increase power consumption.
  - In an area without extreme cold ambient temperatures, which may affect cooling performance.
  - In a cool, well ventilated area, without excessive moisture and high humidity.
- Installing the unit in the coolest area of the room will save energy consumption and running costs.
- To ensure correct operation, this appliance must not be located where the temperature will be below 16°C or above 32°C.
- Ensure there are no obstructions that could prevent the refrigerator door from closing.
- To level the unit, adjust the levelling legs at the bottom of the unit.
- The beverage fridge must have at least 50mm clearance between the rear of the appliance and the wall, 100mm between the sides and wall, and the space above the top should be at least 100mm. Ensure that there is enough spacing to open the door to 160°.
- Before plugging in your new beverage fridge, let it stand upright for approximately 2 hours.** This will allow the refrigerant gases to settle into the compressor and reduce the possibility of a malfunction in the cooling system from handling during transportation.
- The beverage fridge is suitable for connection to 220-240VAC 50Hz supply. The refrigerator must be plugged into a dedicated individual 220-240VAC main socket outlet.
- Plug the unit into an exclusive, properly installed and earthed wall outlet. Do not under any circumstances cut or remove the third (ground) prong from the power cord. If in doubt about your setup, direct any questions concerning power and/or grounding to a certified electrician.
- Do not use an extension cord or an adapter plug.
- Secure the unit's supply cord behind the unit. Do not leave it exposed or dangling to prevent injury and accidental disconnection from the power supply.

**NOTE: After plugging the appliance into a wall outlet, allow the unit to cool down for 2 to 3 hours before placing beverages in the refrigerator compartment.**

8

## Basic Set Up

### Operating your beverage centre

It is recommended you install the beverage center in a place where the ambient temperature is between 22 -25 degree Celsius. If the ambient temperature is above or below the recommended temperature, conditions may cause interior temperature to fluctuate.

If the interior light is left on, the temperature inside the beverage fridge will be higher.

Recommended Temperatures for chilling beverages.

Warmer beverage	7-9 C °
Colder beverage	3-6 C °

The above temperatures may fluctuate depending on whether the bottles are located on the lower/middle or lower section of the appliance and if the interior light is turned on or off.

### How to use the Thermostat

To adjust the temperature of the wine cooler, turn the thermostat knob. Turn the thermostat knob clockwise for a cooler temperature, for a warmer setting turn the thermostat knob anti-clockwise.

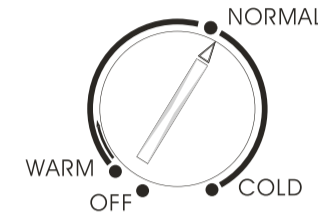

9

## Reversing the Door Swing

This beverage fridge can be opened from either the left side (as supplied) or right side to suit your individual installation requirements. If you want to open the door from the right side, follow the instructions below and opposite to reverse the door swing (the numbers in brackets refer to the parts in the illustrations).

**WARNING!** Ensure the beverage fridge is disconnected from the power supply when reversing door swing.

**NOTE:** Keep all parts you remove for re-installation of the door on the other side.

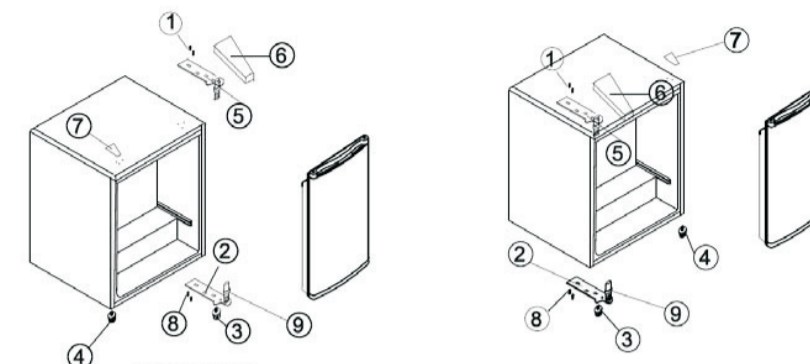

FIGURE 1

Door opening from left side

FIGURE 2

Door opening from right side

- Remove the upper hinge cover (6)
- Remove the two screws (1) that hold the upper hinge (5) (right side) from the frame. Take off the upper hinge (5).
- Lift the door and place it on a padded surface to prevent scratching.
- Remove the two screws (8) that hold the lower hinge (2). Remove the lower hinge (2). If there is originally a washer on the hinge pin, it must remain there while reversing the door.
- If necessary, remove the front levelling legs (4) when reversing the lower hinge and remember to install them after reversing.
- Remove the plug buttons (7) from the holes and place to the right side.
- Set the door in place, make sure it sits on the door seat at the lower hinge (2).
- While holding the door in the closed position secure the upper hinge (5) on the top left hand side with the two screws (1). Do not tighten the two screws (1) until the door is well aligned with the cabinet. Adjust the lower hinge (2) as well if necessary when aligning the door.
- Install the upper hinge cover (7) back onto the upper hinge.

10

## Troubleshooting

If you experience a problem with your beverage fridge, check in the following table for solutions to help you solve the problem. If after these checks you still have a problem with your beverage fridge, call the after sales support line for advice.

Problem	Possible cause
The beverage fridge does not operate.	<ul style="list-style-type: none"> <li>It is not plugged in. Ensure it is properly plugged in and there is power at the socket (plug another appliance into the outlet to check).</li> <li>The circuit breaker tripped or has blown a fuse.</li> <li>The beverage fridge temperature control is set to OFF.</li> <li>A general power outage has cut power to your home (check the household lights).</li> </ul>
The beverage fridge temperature is not cool enough.	<ul style="list-style-type: none"> <li>The room temperature is hotter than normal.</li> <li>A large number of beverages have been added at once.</li> <li>The door is opened too often.</li> <li>The door is not closed completely.</li> <li>The temperature control is not set correctly.</li> <li>The door gasket does not seal properly.</li> </ul>
There are vibrations.	<ul style="list-style-type: none"> <li>The beverage fridge is not level.</li> </ul>
The beverage fridge seems to make too much noise.	<ul style="list-style-type: none"> <li>A rattling noise may come from the flow of the refrigerant, which is normal. A popping and crackling noise may be caused by the contraction and expansion of the inside walls.</li> <li>The beverage fridge is not level, or is touching other furniture.</li> <li>Bottles or packages inside the fridge are touching each other.</li> </ul>
The door will not close properly.	<ul style="list-style-type: none"> <li>The beverage fridge is not level.</li> <li>The door was reversed and is not properly installed.</li> <li>The gasket is dirty or bent.</li> <li>The shelves, racks or crisper are out of position.</li> </ul>
The beverage fridge door will not open.	<ul style="list-style-type: none"> <li>If the door has just been opened, leave it for a few minutes to allow the air pressure to equalise before trying again.</li> </ul>
Moisture forms on the inside or outside walls of the beverage fridge.	<ul style="list-style-type: none"> <li>Hot and humid weather increases the internal rate of frost build-up. This is normal.</li> <li>Open the door less often and make sure it is always properly closed.</li> </ul>

11

## Troubleshooting

The external beverage fridge surface is warm.	<ul style="list-style-type: none"> <li>The exterior walls can be warmer than room temperature. This is normal while the compressor works to transfer heat from inside the beverage center cabinet.</li> </ul>
Excessive frost and ice has built up.	<ul style="list-style-type: none"> <li>The beverage fridge door has been left open.</li> <li>Something is preventing the door from closing.</li> <li>The door gasket is dirty or damaged.</li> <li>Make sure to defrost the fridge center regularly.</li> </ul>
The compressor runs continuously.	<ul style="list-style-type: none"> <li>The temperature is set too cold: select a lower (warmer) setting.</li> <li>The door is open, or something is obstructing proper door closure.</li> <li>The door gaskets are worn, dirty or damaged.</li> <li>Large quantity of beverages has been added to the beverage fridge.</li> <li>The room temperature is hotter than usual.</li> </ul>

12

## Care and Maintenance

### Changing the light bulb

**NOTE:** All parts removed must be saved to do the replacement of the light bulb.

Before removing the light bulb, either unplug the refrigerator or disconnect the electricity leading into the refrigerator, failure to do so could result in electrical shock or personal injury.

### Defrosting the beverage centre

**When?** For the most efficient operation and minimum energy consumption, defrost the appliance when the frost accumulated on the evaporator is about 5mm thick.

**How?** Turn the thermostat dial to the [0] position and unplug the appliance. Remove beverages from the appliance and keep them in another fridge or cooler bag.

Defrosting usually takes a few hours. After defrosting, dry the inside of the appliance and return the thermostat dial to the desired position.

To defrost quickly, remove all beverages from the appliance and leave the door open.

**CAUTION:** Do not use boiling water because it may damage the plastic parts. Never use a sharp or metallic instrument to remove frost as it may damage the cooling system. Use a plastic scraper, if required.

### Cleaning the beverage center

- Unplug the beverage fridge, and remove the bottles.
- Wash the inside with a warm water and baking soda solution. The solution should be about 2 tablespoons of baking soda to a litre of water.
- Wash the shelves and trays with a mild detergent solution.
- The outside of the beverage fridge should be cleaned with mild detergent and warm water.
- It may also be necessary to periodically wipe the bottom part of the storage area, as the beverage fridge is designed to retain humidity and condensation may collect in this area.

### Power failure

Most power failures are corrected within a few hours and should not affect the temperature of your beverage fridge if you minimize the number of times the door is opened. If the power is going to be off for a longer period of time, you need to take the proper steps to protect your contents.

13

## Care and Maintenance

### Vacation Time

During long absences, remove all the bottles; unplug your beverage fridge, clean your beverage center, and leave the door open slightly to avoid possible formation of condensation, mold or odours

### Energy saving tips

- Place the beverage fridge in the coolest area of the room, away from heat-producing appliances and out of direct sunlight.
- Do not line any beverage fridge storage bin with aluminum foil, wax paper or paper towels. Liners interfere with cold air circulation, reducing cooling efficiency.
- Do not leave the beverage fridge door open for longer than required.

### Moving the beverage fridge

- Remove all the bottles.
- Securely tape down all loose items inside your beverage fridge.
- Turn the levelling screws up to the base to avoid damage.
- Tape the doors shut.
- Be sure the beverage fridge stays in the upright position during transportation.

14

## SERVICE AND WARRANTY

Your beverage center is guaranteed against faulty materials and assembly. In the event that warranty service is required, the information provided in this instruction book and the warranty card should be followed. The Warranty Card should be completed at time of purchase and retained with your receipt in the event that warranty service is required.

GAF Control Australia Pty. Ltd.  
441 Kororoit Creek Rd (PO Box 19)  
Altona, Victoria, 3018  
Tel: 1300 659 489

READ AND SAVE THESE INSTRUCTIONS

CKHLL-101