

HELLER

Instruction Manual

50cm Pedestal Fan

Model: HPF50W



READ AND SAVE THESE INSTRUCTIONS

Please read and follow the instructions in this user manual even if you feel you are familiar with the product, and find a place to keep it handy for future reference.

For your convenience record the complete model number (located on the product identification plate) and the date you received the product, together with your purchase receipt and attach to the warranty and service information. Retain in the event that warranty service is required.

NOTE: The rating of this product (as marked on the product identification plate) is based on specific loading tests. Normal use or the use of other recommended attachments may draw significantly less power.

IMPORTANT SAFEGUARDS

When using any electrically powered product, basic safety precautions should always be followed, including the following:

PLEASE READ ALL INSTRUCTIONS CAREFULLY BEFORE USING THIS PRODUCT

WARNING! - to reduce the risk of fire, electrical shock or injury to persons or property:

- Always operate the product from a power source of the same voltage, frequency and rating as indicated on the product identification plate.
- Remove the unit from its packaging and check to make sure it is in good condition before using.
- Do not let children play with parts of the packaging (such as plastic bags).
- Close supervision is necessary when the product is used by or near children or infirm persons. Do not allow children to use it as a toy.
- Do not operate any product with a damaged cord or plug, or after the product malfunctions, or is dropped or appears damaged in any way. Return the complete product to the place of purchase for inspection, repair or replacement.
- Before unplugging the power cord, be sure to turn the power off. When touching the unit, be sure your hands are dry to prevent electrical shock.
- Never install the unit where it is exposed to direct sunlight, excessive moisture/rain, dust and lack of ventilation near any heat sources.
- Avoid making contact with moving parts. Never insert fingers, pencils or any other objects through the guards whenever the power plug is connected, especially while the unit is working.
- Always place the fan on a stable, level surface when operating to prevent the fan from overturning. Do not run the power cord under carpet. Do not cover the power cord with throw rugs or runners. Route the power cord away from walking paths so that nobody can trip over it. The cable should be kept away from heat, sharp edges and oil.
- To reduce the risk of electric shock, do not immerse or expose the product or flexible cord to rain, moisture or any liquid other than those necessary for correct operation of the product.

- This product should not be used in the immediate vicinity of water, such as bathtub, washbowls, bathroom swimming pool etc. Where the likelihood of immersion or splashing could occur.
- Switch off and unplug from outlet when not in use, before assembling or disassembling parts and before cleaning. Remove by grasping the plug - do not pull on the cord.
- Be sure that no other high current appliances are plugged into the same circuit as your fan, as an overload can occur.
- Avoid the use of an extension cord as the extension cord may overheat and cause a risk of fire.
- Do not use the appliance for other than its intended use.
- Do not use outdoors. **FOR INDOOR USE ONLY.**
- Do not leave the appliance unattended when switched on.
- Do not cover the grill, or operate in close proximity to curtains etc.
- The use of attachments or accessories not recommended or sold by the product distributor may cause personal or property hazards or injuries.
- This product is intended for normal domestic/household use only.
- Never leave a working appliance unattended, even for a short period of time – always switch it off. Please unplug the appliance from the power supply when not in use.
- Use this fan as described in this manual. Any other uses, not recommended by the manufacturer, may cause fire, electric shock, or injury to persons and may void the warranty.
- This appliance is not intended for use by persons (including children) with reduced physical, sensory or mental capabilities, or lack of experience and knowledge, unless they have been given supervision or instruction concerning the use of the appliance by a person responsible for their safety.
- The installation of a residual current device (safety switch) is recommended to provide additional safety protection when using electrical appliances. It is advisable that a safety switch with a rated residual operating current not exceeding 30mA be installed in the electrical circuit supplying the appliance. See your electrician for professional advice.
- Children should be supervised to ensure that they do not play with the appliance.
- Do not leave the fan running unattended.
- **WARNING:** If the supply power cord is damaged, the power cord must be replaced by the manufacturer, its service agent or similarly qualified persons in order to avoid a hazard.
- This product has not been designed for any uses other than those specified in this booklet.
- **CAUTION:** Never insert your fingers or any other objects (hair, clothes, utensils, knives, screw drivers etc.) into the openings of the guard or close to the blade when the appliance is connected to the power supply.
- **CAUTION:** DO NOT COVER the appliance in any way in order to avoid overheating and fire.
- **CAUTION - RISK OF ELECTRIC SHOCK:** To reduce the risk of electric shock do not open this device, there are not serviceable parts for customers. Please refer any maintenance or repair to qualified personnel.

SAVE THESE INSTRUCTIONS

FEATURES OF THIS PRODUCT

1. Front Grille
2. Blade Cap
3. Blade
4. Plastic Mounting Nut
5. Rear Grille
6. Motor Shaft
7. Oscillating Knob
8. Motor Housing
9. Front Control box
10. Speed Control box
11. Back Control box
12. Height Adjustment Collar
13. Screw (4pcs)
14. Stand Cover
15. Stand
16. Nuts (4pcs)
17. Grille Screw

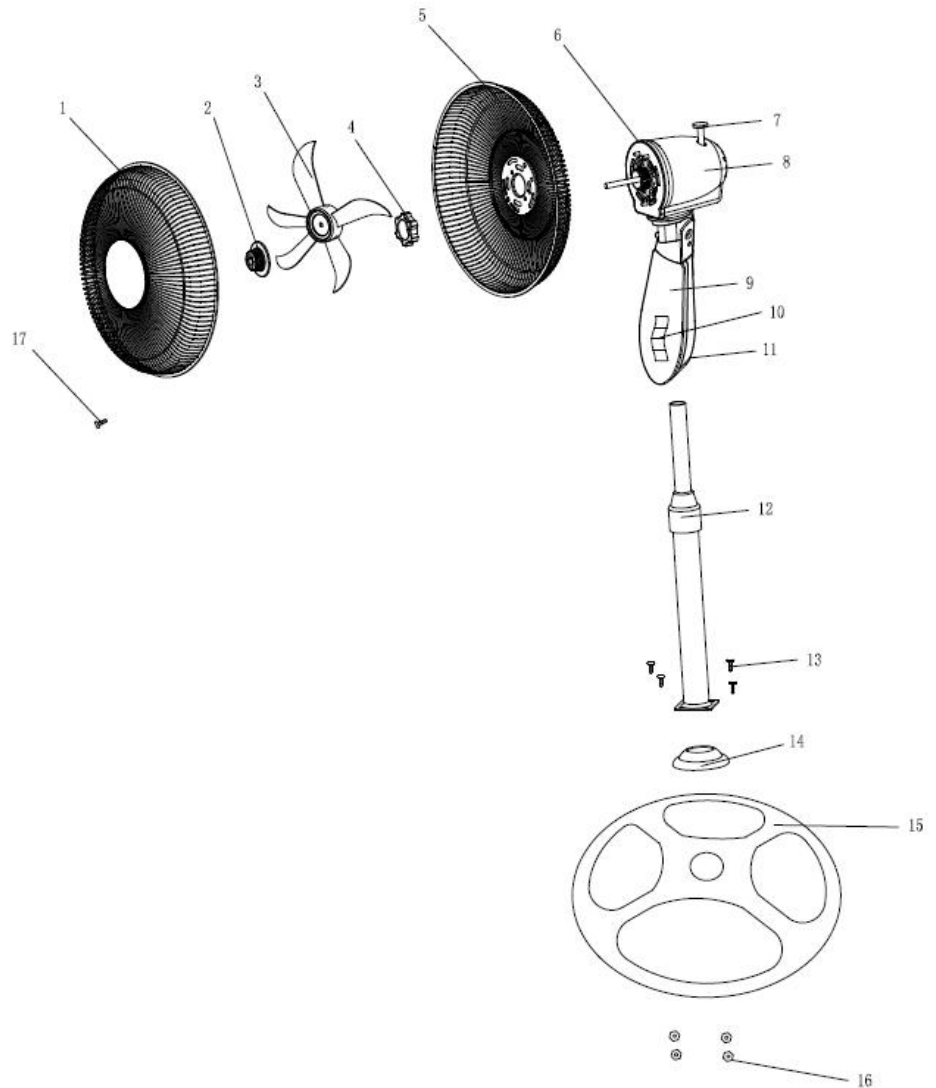

ASSEMBLY INSTRUCTIONS

Grills, fan blades and the main body of the fan are packed separately to protect your fan from damages during transportation.

1. Attach the column to the stand with the 4 screws.
2. Unscrew and take off the Height Adjustment Collar
3. Slide the stand cover down the column to rest on the stand.
4. Pull out the extension tube from the inside of column and refit the Height Adjustment Collar. **CAUTION:** The height adjustment screw must be fully Tightened before assembling the motor section to the pedestal stand.
5. Fit the motor section to the pedestal stand and tighten the screw. **CAUTION:** The thumbscrew must be fully tightened before the fan is operated.
6. To assemble the grille and blade, remove the Blade Cap by turning it clockwise remove the fan blade and then remove the Plastic Mounting Nut by turning it clockwise from the motor shaft.
7. Put the rear grille into position. Ensure the rear grille fits onto the Locating pins. Then fix the rear grille using the plastic Mounting Nut.
8. Put the fan blade on the motor shaft and tighten the Blade Cap anticlockwise.

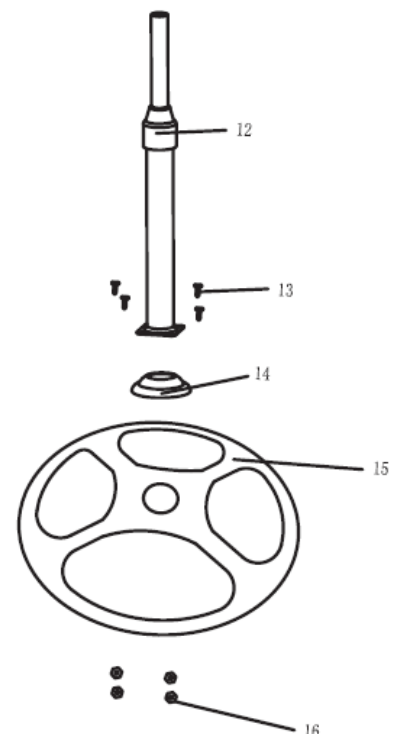

- Put the front grille onto the rear grille, fix with the locking clips then fasten the grille screw.

BEFORE FIRST USE

Before use, remove all packaging and inspect the appliance for any damage. If there appears to be any damage, please take the unit back to place of purchase for a replacement.

OPERATING INSTRUCTIONS

NOTE: Before inserting the plug into a power outlet, make sure that the correct voltage being used corresponds to what is indicated on the rating label, and that the socket has an earth facility.

CAUTION:

- Select a suitable location for the fan. Always choose a safe location in accordance with the safety recommendations outlined.
- To avoid of electric shock, you must always switch off and unplug the unit before cleaning.
- The fan should always be switched off when making any adjustments to the fan head angle.

- Push the button for the required fan speed: '0' for 'OFF', '1' for Low Speed, '2' for Intermediate Speed and '3' for High Speed.
- To make the fan head oscillate, push the oscillating knob DOWN. To stop the oscillation, pull the oscillating knob UP.
- To adjust the tilt of the fan head, simply tilt the fan head to the desired angle. The head can latch in one of three positions.

CAUTION: *The fan should be switched off when making this adjustment.*

NOTE: *The head will not latch into the low or mid position until the guard and blade are fitted to the motor.*

- To adjust the height of the pedestal fan, loosen the eight adjustment screw carefully raising or lowering the fan and firmly re-tighten the height adjustment nut.

CARE & CLEANING

NOTE: If the power cord set of this appliance becomes damaged, discontinue use. Repairs should be undertaken only by a qualified technician.

CAUTION:

- To avoid of electric shock, you must always switch off and unplug the fan before cleaning.
- Do not use harsh detergents, chemical cleaners or solvents as they may damage the surface finish of the plastic components and the paint finish.

- Your appliance must be switched OFF via the main power supply and unplugged, and allow it to cool down before proceeding with any cleaning, assembling or disassembling.
- Clean the housing with a damp cloth, a vacuum cleaner or a dusting brush.
- We recommended lightly running a vacuum cleaner brush nozzle over the fan grille to remove any dust or dirt that may have accumulated.
- Do not immerse the fan in water and never allow water to drip onto the motor or switch housing.
- To clean the fan blade, remove the guard locking screw and disengage the clips holding the front guard to the rear guard.
- Remove the front guard.
- Wipe the blade and guards.
- Reassemble the guards first before storing the fan in its original carton or cover it to protect it from dust. Store it in a cool, dry place.

SPECIFICATIONS

Model	Description	Voltage	Frequency	Wattage
HPF50W	50cm Pedestal Fan	220-240V~	50Hz	90W

RECYCLING

For further information, please contact your local or regional authorities.

Electronic products not included in the selective sorting process are potentially dangerous for the environment and human health due to the presence of hazardous substances.



CUSTOMER SERVICE

Australian Customer Service

GAF Control (Sales) Pty Ltd

P.O Box 19

Altona North Victoria 3025

Phone: 1300 659 489

Hours: 9am-5pm (EST) Mon-Fri

www.gafcontrol.com.au

*This product may vary slightly to the product illustrated due to ongoing product development.