

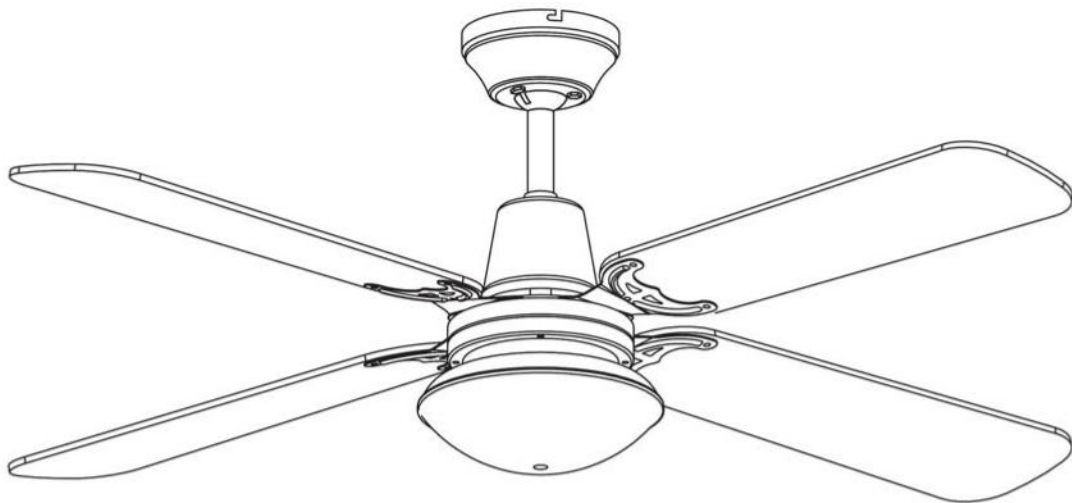

CEILING FAN INSTALLATION MANUAL



Fan picture is for illustration purpose only. Styles will vary according to the particular models.

OWNERS INSTRUCTION MANUAL

- INSTALLATION
- OPERATION
- MAINTENANCE

CAUTION

**READ INSTRUCTIONS CAREFULLY FOR SAFE FAN
OPERATION. CONTACT
A QUALIFIED ELECTRICIAN FOR INSTALLATION**

**These instructions are suitable for
SAA Listed Ceiling fans**

CONGRATULATIONS ON YOUR CHOICE

CONGRATULATIONS, as you have just chosen a quality ceiling fan.

SAFETY PRECAUTIONS

The information contained in the following pages has been prepared to ensure you of trouble-free operation of your Ceiling Fan .

1. To ensure the success of the installation be sure to read the instructions and study the diagrams thoroughly.
2. All electrical work must only be undertaken after disconnection of the power by removing fuses or turning off the circuit breaker, to ensure all pole isolation of the electrical supply. Installation may only be done by a qualified electrician and the work performed in accordance with the local regulations, current good practice and other national and local electrical codes.
3. Make sure that the installation site will not allow the rotating fan blades to come into contact with any object and that there is a minimum clearance of 150mm (6") from the blade tip to the wall or ceiling. Please note that the bigger this clearance is the better the airflow from your fan will be. Ensure the blades are mounted at a minimum height of 2.1 meters from the floor when the fan is installed.
4. The fixing point for the fan must be able to support a weight of ten times that of the net weight of the fan. Net weights can be found on the bottom of the unit's box. If you are mounting the fan to a ceiling junction box, the box and it's fixing must be able to support the moving weight of the fan and must not twist or work loose.
5. The fan must be earthed.
6. Do not connect the fan motor to a dimmer switch. This may give an unsatisfactory performance (motor hum) and cause damage to the motor.
7. It is not recommended that ceiling fans and gas appliances be operated in the same room at the same time.
8. The fan must be turned off and stopped completely before reversing the fan direction. This will prevent any damage to the motor of the unit or controller (if installed).
9. Do not insert anything into the fan blades while the fan is operating. This will damage the blades and upset the balance of the unit causing the unit to wobble.
10. After the fan is completely installed make sure that all connections are secured and tightened to prevent any problems.
11. Because of the fan's natural movement, some connections may loosen. Check the support connections, brackets and blade attachments twice a year to make sure they are all secured. If they are loose, tighten with a screwdriver.

Note: The important safeguards and instructions given in this manual are not meant to cover all possible conditions and situations that may occur. It must be understood that common sense, caution and care are factors, which cannot be built into any product. The persons caring for and using the unit must supply these factors.

Consult only licensed electrical contractor for installation. In the unlikely event of damaged or missing parts, refer to the In Home Warranty contact details listed on the Warranty card or the original place of purchase.

IMPORTANT NOTES

FAN CONTROL

Your warranty will be void if a solid-state dimmer type fan controller or other band Remote controller is used.

With these controllers there is a strong possibility that the ceiling fan motor will produce an unpleasant load humming noise.

FAN INSTALLATION

Under our warranty terms, this ceiling fan must be installed by a licensed electrician. Improperly installed ceiling fans can be dangerous and expensive to repair. Warranty is void if not installed by a licensed electrical contractor. This fan is designed for indoor use only, mounting where the fan is subject to water or moisture is dangerous. Any change to external finish is not covered by warranty.

FAULT FINDER

Always check the "Trouble Shooting Checklist" included in this booklet before calling for service. Unnecessary calls are inconvenient for all and can attract a service charge.

MECHANICAL NOISE MAY BE NOTICED ON INSTALLATION-ALLOW AT LEAST 8 HOURS SETTLING-IN PERIOD. SOME FANS MAY WOBBLE MORE THAN ANOTHER—EVEN IN THE SAME MODEL, IT DOES NOT NECESSARILY INDICATE THE FAN IS FAULTY.

WARNING

The appliance is not intended for use by young children or infirm person without supervision.

Young children should be supervised to ensure that they do not play with the appliance.

The fan must be installed so that the blades are more than 2.1 meters above the floor.

The important safeguards and instruction appearing in this manual are not meant to cover all possible conditions and situation that may occur. It must be understood that common sense, caution and care are factors, which cannot be built into any product. These factors must be supplied by the person(s) caring for and operating the unit.

INSTALLATION INSTRUCTIONS

-----Part List---

1. Ceiling fixture
2. Screws fixing canopy and mounting plate
3. Terminal block
4. Hanger ball
5. Upper canopy
6. Screws fixing mounting plate and ceiling
7. Downrod
8. Lower canopy
9. Screws fixing blade to motor
10. Reverse switch
11. Blade
12. Motor
13. Decorative knob

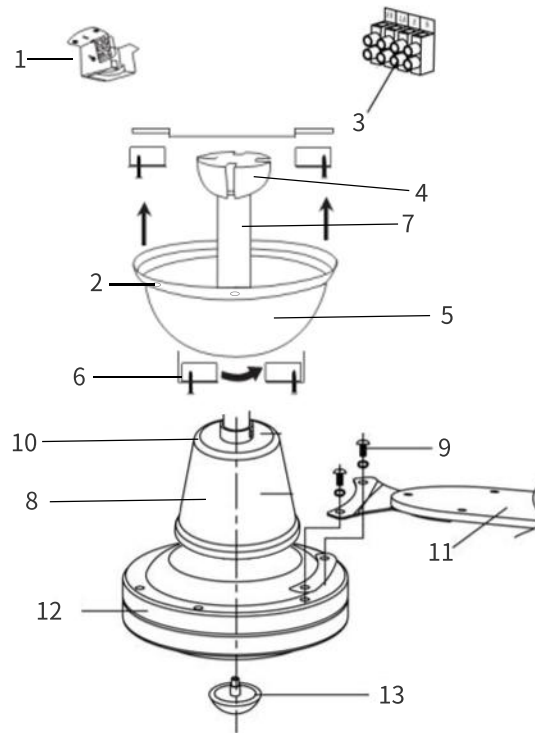

ASSEMBLY

1. DETERMINE A SUITABLE POSITION TO MOUNT THE CEILING FAN

CAUTION: Installer, before installing the fan, make sure you have turned OFF electricity supply.

If it is necessary to reduce the length of the downrod, please ensure that the cut is made clean and square, that all burrs are removed and the locating hole is drilled true and square. If this hole is drilled out of square, you will introduce an out of balance characteristics to the fan, which is not covered by warranty.

Choose a location for mounting the fan where the blade will have at least 2.1M of clearance from the floor. If the location you have chosen does not have a suitable support beam, install a 2 x 4" brace between the ceiling joists as a support medium. .

2. MOUNTING THE CEILING PLATE

Secure the metal fixture to the ceiling with screws provided.



3. SETTING BLADES AND THEIR HOLDERS

Connect the blade holder to blade by screws provided. Repeat the procedure for remaining blades.

For metal blades fan, the blade bracket is pre-assembled in factory. Use care to avoid bending blades or brackets.

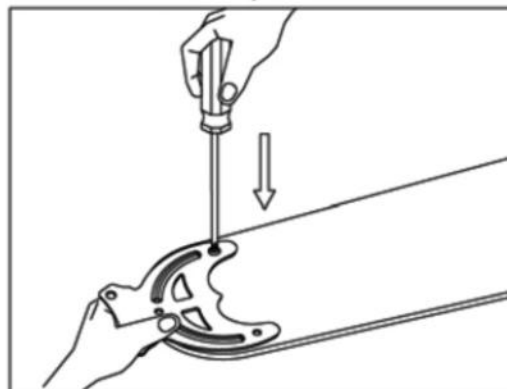

4. CONNECTING BLADE SETS TO MOTOR

Connect the blade bracket to the motor by screws and washers provided. Repeat the procedure for all remaining blades. Ensure all screws are tight. Loose screws may cause undue noise in operation.

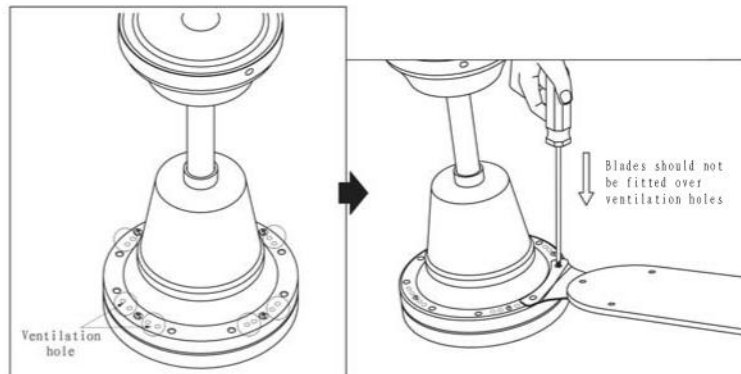

5. PUTTING THE FAN INTO THE MOUNTING BRACKET:

Place the assembled fan into small J hook from the mounting plate and make the wiring connection

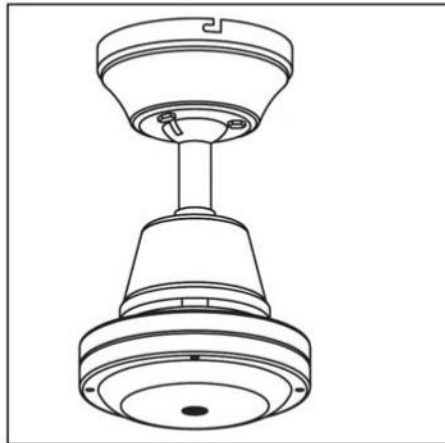

TRUE BALANCE SYSTEM:

Some ceiling fan will employ TRUE BALANCE HANGER SYSTEM, please make the installation as bellows:

On upper canopy, install downrod into true- balance canopy by first inserting downrod and ball assembly into large opening in canopy, making sure canopy engages notch in downrod ball (see insert). Finger tighten clamp ring onto downrod ball using bolt provided (these bolts will be further tightened in next step)

Next step. After fan is installed and hanging straight. Tighten the anti-wobble canopy bolts with pliers or wrench to eliminate wobble during operation. NOTE: Over tightening bolts may damage canopy.

Wiring connection

Carefully connect the wires as:

A/ fan ACTIVE wire from ceiling to "FA", BROWN wire on terminal, from fan as LIVE/ACTIVE connection

B/ light ACTIVE wire from ceiling to "LA", WHITE wire on terminal from fan/light kit as LIVE/ACTIVE connection

C/ NEUTRAL wire from ceiling to "N", BLUE wire on terminal from fan as NEUTRAL connection

D/ EARTH wire from ceiling to "E", Green or GREEN/YELLOW wire on terminal from fan as EARTH connection

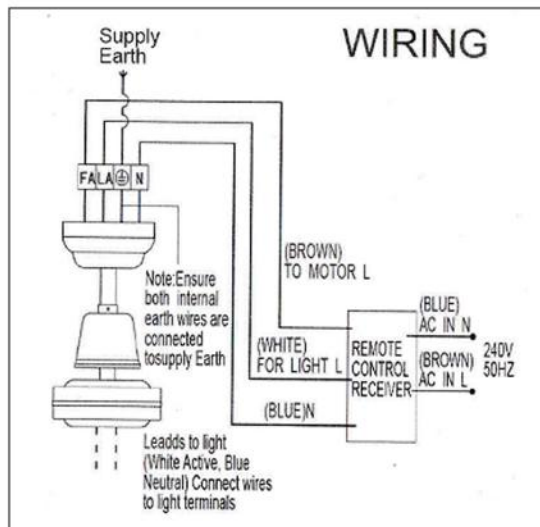

Ensure all wires are arranged in a tidy fashion, and make sure you can place the ball to sit well into the bracket. This is important to make sure the fan is free from wobbling.

Align the open slotted holes with the two screws inserted. Give the fan a slight turn until the washers align with the closed end of the slotted holes. Insert the remaining two screws and washers in the remaining two holes of the canopy. Tighten all screws.

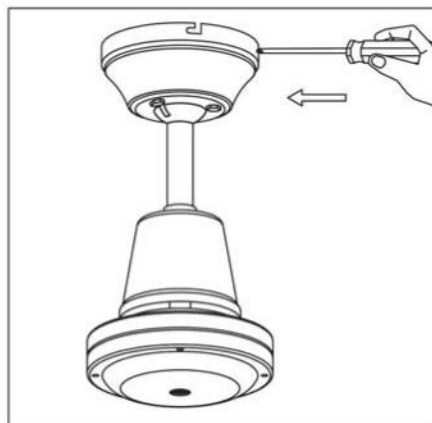

6. INSTALL DECORATIVE NUT

Screw the decorative nut into the end of the motor shaft if the ceiling fan has no light kit. Then go to step THREE SPEED FLUSH CONTROL SETTING

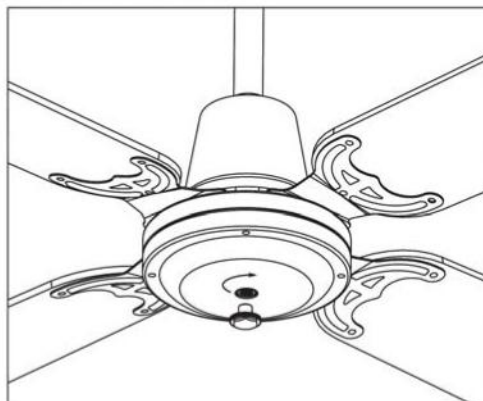

7. LIGHT CONNECTION (OPTIONAL):

If the fan has a light kit. Please install the light kit in the following steps:

LIGHTING DIAGRAM

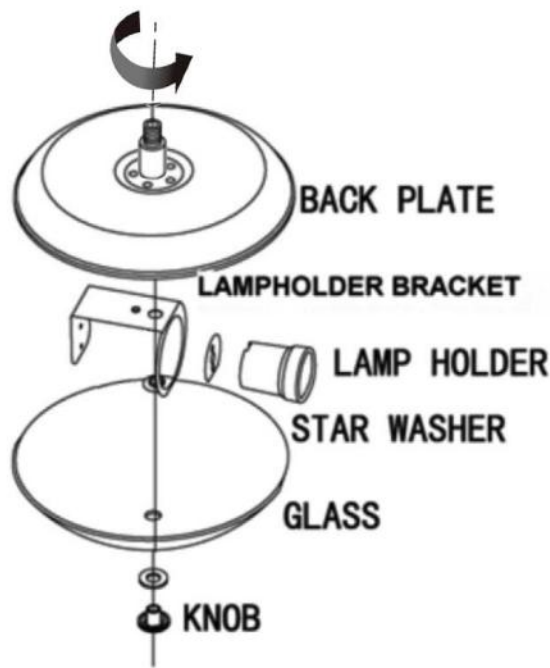

A/Get the protruding wires from base of motor. Fit fiberglass insulating sleeve over wires from the base of motor

B/ screw up the adaptor with the star washer to the back plate of oyster light kit

C/Get the wires with fiberglass insulating sleeve via the adaptor into the oyster light kit and connect wires to the terminal block. **WARNING: MAKE SURE "ACTIVE" to "ACTIVE; "NEUTRAL " to " NEUTRAL" of lampholder.**

Incorrect connection may cause the light to not work and may be dangerous.

D/ excess insulation sleeving should be fed back into motor body.

E/ fit recommended light bulb(s). Ensure insulating sleeving is kept clear of bulb.

F/ fit the glass to the back plate and insert the knob to the glass (for oyster only, clipper does not require knob)

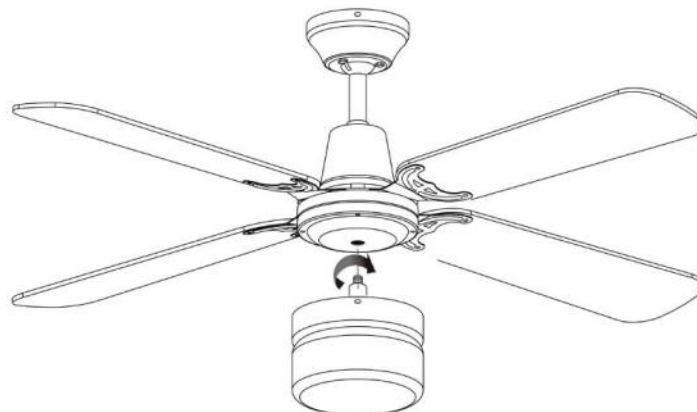

This procedure is also applicable to the clipper light kit. Other types of light kit follow a similar procedure .

8. THREE SPEED FLUSH CONTROL SETTING

Make the wire connection (See Wiring Instruction)

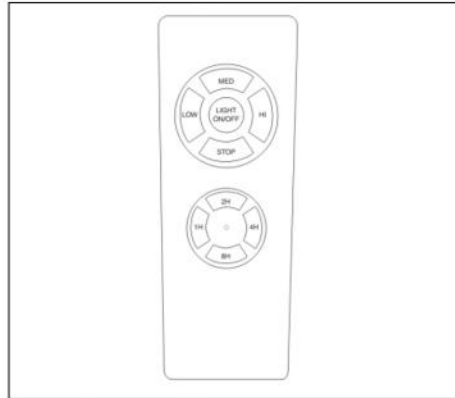

Note: use supplied remote controller only, as a different controller may not be compatible, and may cause the fan to operate incorrectly. Incorrectly installed controls are not covered by warranty.

A/ the speed control shall fit into existing gang block or wall plate. If the control cannot be flush mounted, use a standard single gang mounting block.

B/ connect the wires as indicated on the control. A for ACTIVE, F for the fan load.

Reverse connection of speed control will affect the operation of the fan.

C/ Select the desired position of the reverse switch on the lower canopy of the fan.

Warmer Weather ---Have the airflow directed downwards.

Cooler Weather ---Have the airflow directed upwards.

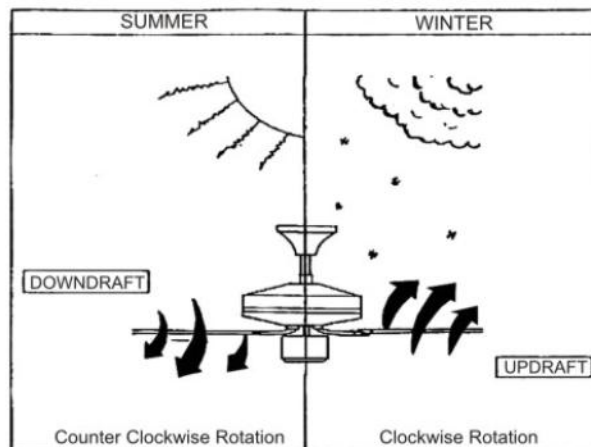

D/ some wall controller may have the light switch on it for light kit on /off switching.

Switch on power and test ceiling fan and light after completing all wiring connections. If you find any problem, please check the "Trouble Shooting Checklist" included in this booklet before calling for service. Unnecessary calls are inconvenient for all and can attract a service charge.

MECHANICAL NOISE MAY BE NOTICED ON INSTALLATION-ALLOW AT LEAST 8 HOURS SETTLING-IN PERIOD.

REMEMBER, SOME FANS MAY WOBBLE SLIGHTLY, ESPECIALLY ON HIGH SPEED.

9. CORRECTING ANY WOBBLE EVIDENT

Please note that all ceiling fans are not the same, even in the same model—some may move more or less than others. Movement of a couple of centimeters is quite OK and does not suggest the fan will fall down.

Even all blades are weighted and grouped by weight, it is impossible to eliminate wobble altogether and should not be considered a problem. Ceiling fans tend to move slightly during operation because they are not generally rigidly mounted.

The following should be performed to reduce any evident wobble.

A/ Check all the blade brackets are tightened securely.

B/ Wobble may result from inconsistent blade level. To check blade level, measure the distance from each blade tip to the ceiling. If measurements are inconsistent, adjustment of the brackets will be required. All measurements must be the same.

C/ Blade tracking may be checked simply by use of a household yardstick as shown in below Figure. Place the yardstick vertically against the ceiling and even with the outside leading edge of a blade. Note the distance of the edge of a blade same as others. Turn the blade slowly by hand to check the remaining blades. If a blade is not in alignment, the blade holder may be gently bent up or down to be in line with the other blades.

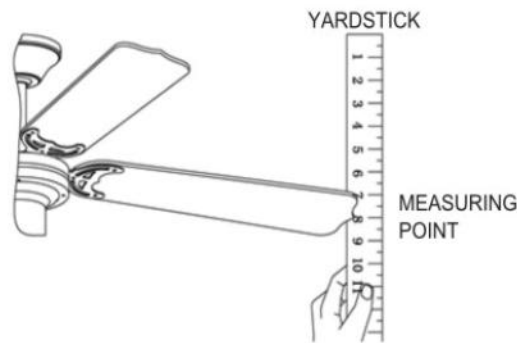

D/ Some fan movement is normal. However, interchanging an adjacent (side by side) blade pair may redistribute the weight and result in smoother operation.

FOR 4 BLADES MODELS

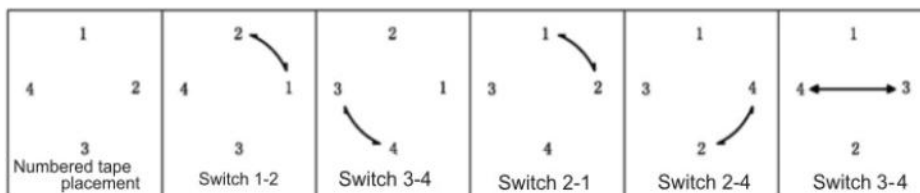

FOR 5 BLADES MODELS

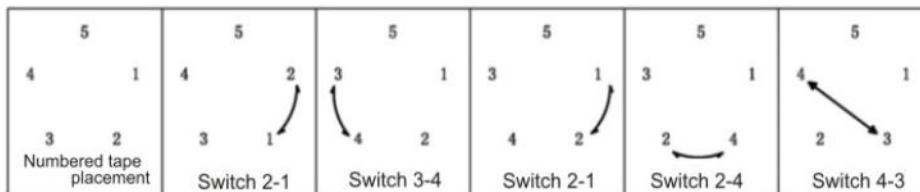

10. CARE & CLEANING

- Periodic cleaning of your ceiling fan is the only maintenance required. Use a soft brush or lint free cloth to avoid scratching the finish. Please turn off electricity when you do so.
- Do not use water when cleaning your ceiling fan. It could damage the motor or the wood blades and create the possibility of an electrical shock
- Motor has permanently lubricated ball bearing. No need to oil

FAN CARE AND WARRANTY INFORMATION

WARRANTY SERVICE

The manufacturer warranty covers actual faults that may develop, but NOT minor complaints, e.g. hearing slight noise from motor in operation—ALL ELECTRIC MOTORS ARE AUDIBLE TO SOME EXTENT.

WOBBLE

- Ceiling fans tend to move during operation because they are not generally rigidly mounted—if they were, they could generate excessive ceiling vibration and stress on their mountings.
- Movement of a couple of centimeters is quite OK and does not suggest the fan will fall down.
- Ceiling fans are mounted very securely on steel brackets with rubber cushioning or with ball-joints to allow free movement.
- Please note that all ceiling fans are not the same, even in the same model—some may move more or less than others.

NORMAL WEAR AND TEAR

Threaded components working slightly loose or blade carriers even slightly bent due to vigorous cleaning or bumping can cause extra wobble and noise. THIS IS NOT COVERED UNDER WARRANTY- but a little care and maintenance can reduce or prevent this problem.

BUMP-IN-THE NIGHT

This is the biggest cause for service calls, which are outside the manufacturer's warranty. If a fan has a fault, it will be noticeable at all times. Naturally, when everything is quiet at night, you will be more inclined to hear small noises, which may not be noticeable at other times. Even slight power fluctuations, and mains frequency signals superimposed in your electricity supply for off-peak hot water control may cause a change in fan motor noise. This is normal.

FAN LIGHT

FAN LIGHTS ARE NOT COVERED UNDER IN HOME WARRANTY. Noises and vibration etc are often more accentuated when a fan light is fitted. GLOBES ARE NOT COVERED UNDER WARRANTY
For instance, a fan light glass that has not been tightened or worked loose can cause a rattle. Again, care and maintenance will reduce this
Any problem with any glass of a light kit should be advised to the place of purchase on opening the box.

WARNING

- The appliance is not intended for use by young children or infirm person without supervision.
- Young children should be supervised to ensure that they do not play with the appliance.
- The fan must be installed so that the blades are more than 2.1 meters above the floor.
- According to law in Australia, ceiling fans must be installed by licensed electrician
- According to our warranty terms, only fans installed by a licensed electrician have cover for warranty service

TROUBLE-SHOOTING CHECKLIST

TROUBLE	PROBABLE CAUSES	SUGGESTED REMEDY
1. Fan will not start	A/ Fuse or circuit breaker blown. B/ Loose power line connections to the fan. C/ Speed controller not in correct position.	A/ Check main and branch circuit fuses or circuit breakers. B/ Check line wire connections to fan C/ Check speed controller's position.
2. Fan Wobbles	A/ Fan blades are not horizontal to ceiling. B/ Blade screws are loose.	A/ Measure from ceiling to tip of blades, then rotate fan so all blades are checked for equal height from ceiling (not adjustments may be made by slight pressure up or down on blade holders). Make sure all screws are securely fastened.
3. Fan sound noisy	A/ Top canopy touching ceiling. B/ Loose fan blade screws. C/ Ceiling fan not secured against ceiling. D/ Incorrect speed controller.	A/ Lower Canopy from ceiling to ensure minimum 3 mm clearance. B/ Re-tighten all screws on fan blades but never over-tighten. C/ Re-tighten all screws in the hanging bracket or plate. D/ Change the controller to the one supplied.
4/ Mechanical Noise	A/ Allow at least for 8 hours settling-in period.	

NOTES TO INSTALLERS

- All electric motors, including fans make some noise and may feel hot if touched—This is not a fault.
- Some fans may wobble more than another—even in the same model.
- Fan lights may rattle. This is not covered under warranty
- Fan wall controller may make a slight buzz and get warm especially on lower setting

These occurrences are not covered by the manufacturers warranty.

WARRANTY CONDITIONS

This product is guaranteed against electrical defects in material or manufacturing workmanship for faults when under normal domestic conditions for a certain period of time (pls refer to the warranty card for duration) from the date of purchase. This warranty covers parts and labour costs for the motor subject to the following conditions:

1. Installation being performed by a qualified licensed Electrician.
2. This warranty will not apply if the ceiling fan is installed by other than a licensed electrician. Problems arising from incorrect installation are not covered by warranty. The cost of repairs and/or service call where the defect is due to the installation and not due to faulty material or workmanship, in accordance with wholesaler and their authorized agent, will be payable at time of repair.
3. The correct controller being fitted to the fan

Only use the controller supplied with the fan or a genuine replacement. Using solid-state dimmer type or non-genuine controllers will void the warranty. Use of non-genuine controllers may cause the fan to operate with a loud hum and at altered speeds. Where controllers are supplied complete with light switch – do not use this switch to operate the fan. Fans connected using this switch to turn the fan on/off, will not be covered by warranty.
4. Repair work being carried out by approved electrician only after authorisation by wholesaler or their authorised agent to complete the repair and is subject to the supply of dated proof of purchase and installing electricians details.
5. The serviceable area governing in-home service to be as defined by wholesaler and their authorized agent.
6. The exclusion from warranty of any changes to ceiling fan blade, plated and/or painted finishes due to climatic conditions or other circumstances deemed to be beyond the control of wholesaler or their authorized agents.
7. The warranty service does not cover:
 - a. Traveling costs incurred where service is requested at premises, or areas deemed to be outside the agents service zone, or at times outside normal servicing hours, as defined by wholesaler or their authorized agent.
 - b. Transportation and in-transit insurance costs, if the product or parts thereof have to be returned for repair or replacement to wholesaler or their authorized agent.
 - c. Repair of defects caused by accident, fire, misuse, alterations modification, negligence, incorrect or incomplete installation/operation, any unauthorized person attempting to repair the ceiling fan, or acts of God.
 - d. Claims or damage to furniture, carpet, wall, ceiling foundations or any other consequential loss either direct or indirectly resulting from a faulty ceiling fan.

8. Except in the case of pre-packed light complete models, light fittings attached to the fan are not covered by this warranty. Where the fan is pre-packed complete with a light, the light fitting will be covered by warranty to electrical defect. Tarnishing caused by climatic conditions and breakage of glasses is not covered by warranty. Globes/lamps are also not covered by warranty. Any light fitting attached to the fan must be installed by a qualified licensed Electrician ensuring such attachments are complete and do not affect the fan's performance. Light fittings will often accentuate noises and vibrations, which can be traced to loose glasses or fittings and are not covered by warranty. Broken glass as supplied in the pre-packed light complete models is not considered an item requiring a warranty service call. Notification within 48 hours of installation is required where glasses have found to be broken on unpacking.
9. The warranty applies to actual faults, which may develop. Minor running noises are not covered. All electrical motors have some audible noise. Allow at least eight hours of operation to allow the bearings to properly seat. The fan, especially when set on low, may feel warm to touch – this is not a fault. If excessive heat is generated a service call may be required. Fan noises can vary due to slight power fluctuations and mains frequency signals for off – peak controlled appliances. These changes are most noticeable in the quiet of night.
10. Threaded components such as blade nuts can work slightly loose during normal operation. These should be tightened regularly to ensure the fan doesn't develop operation noises. If noises do develop, check this aspect before requesting service. This is not covered by warranty.
11. Minor variation of speed may be evident between different fans, even in the same model and is not a product fault and not covered by warranty.
12. Blades are not covered by warranty against defect in material. The replacement of the blades is not covered by the in home warranty service call, Notification within 48 hours of installation is required where blades have found to be broken on unpacked, access wholesaler or their authorized agent who will send you spare part at your delivery cost. Blades affected by climatic conditions and by maintenance are not covered by this warranty.

This warranty applies only to Australian states, it's mainland territories and New Zealand. The benefits of this warranty are in addition to any benefits offered under state or territory law.

For under warranty service, contact wholesaler or their authorized agent and advise: model number and style, the nature of the fault, date and place of purchases. Service can not be arranged without this information.

Prior to requesting service, please consult the Trouble-shooting check list.

- All electric motors, including fans, make some noise and may feel hot to touch – this is not a fault.
- Some fans wobble more than others – even the same model.
- Blades are weighed to be within tolerance to minimise wobble. In multiple installations do not mix blades from fans.
- Blade carriers can be easily bent. This is another cause of fan wobble. Ensure the blades and carriers/holders are attached to the motor only after it is hung or use a cradle so the carriers/holders are not damaged.
- Fan lights can rattle and are not covered by warranty.
- Finish to the fan, including blades and light complete models, are covered by 6 months warranty.
- Blade and glass replacement are not covered by in home servicing.